



UNIVERSITY OF CAMBRIDGE INTERNATIONAL EXAMINATIONS
General Certificate of Education
Advanced Subsidiary Level and Advanced Level

MATHEMATICS

9709/12

Paper 1 Pure Mathematics 1 (P1)

October/November 2010

1 hour 45 minutes

Additional Materials: Answer Booklet/Paper
Graph Paper
List of Formulae (MF9)



READ THESE INSTRUCTIONS FIRST

If you have been given an Answer Booklet, follow the instructions on the front cover of the Booklet.

Write your Centre number, candidate number and name on all the work you hand in.

Write in dark blue or black pen.

You may use a soft pencil for any diagrams or graphs.

Do not use staples, paper clips, highlighters, glue or correction fluid.

Answer **all** the questions.

Give non-exact numerical answers correct to 3 significant figures, or 1 decimal place in the case of angles in degrees, unless a different level of accuracy is specified in the question.

The use of an electronic calculator is expected, where appropriate.

You are reminded of the need for clear presentation in your answers.

At the end of the examination, fasten all your work securely together.

The number of marks is given in brackets [] at the end of each question or part question.

The total number of marks for this paper is 75.

Questions carrying smaller numbers of marks are printed earlier in the paper, and questions carrying larger numbers of marks later in the paper.

This document consists of **5** printed pages and **3** blank pages.



- 1 (i) Find the first 3 terms in the expansion, in ascending powers of x , of $(1 - 2x^2)^8$. [2]
- (ii) Find the coefficient of x^4 in the expansion of $(2 - x^2)(1 - 2x^2)^8$. [2]

2 Prove the identity

$$\tan^2 x - \sin^2 x \equiv \tan^2 x \sin^2 x. \quad [4]$$

3 The length, x metres, of a Green Anaconda snake which is t years old is given approximately by the formula

$$x = 0.7 \sqrt{(2t - 1)},$$

where $1 \leq t \leq 10$. Using this formula, find

- (i) $\frac{dx}{dt}$, [2]
- (ii) the rate of growth of a Green Anaconda snake which is 5 years old. [2]

4

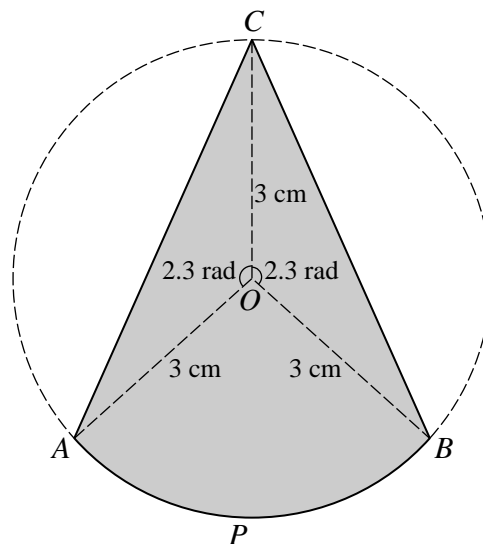

The diagram shows points A, C, B, P on the circumference of a circle with centre O and radius 3 cm. Angle $AOC =$ angle $BOC = 2.3$ radians.

- (i) Find angle AOB in radians, correct to 4 significant figures. [1]
- (ii) Find the area of the shaded region $ACBP$, correct to 3 significant figures. [4]
- 5 (a) The first and second terms of an arithmetic progression are 161 and 154 respectively. The sum of the first m terms is zero. Find the value of m . [3]
- (b) A geometric progression, in which all the terms are positive, has common ratio r . The sum of the first n terms is less than 90% of the sum to infinity. Show that $r^n > 0.1$. [3]

6 A curve has equation $y = kx^2 + 1$ and a line has equation $y = kx$, where k is a non-zero constant.

(i) Find the set of values of k for which the curve and the line have no common points. [3]

(ii) State the value of k for which the line is a tangent to the curve and, for this case, find the coordinates of the point where the line touches the curve. [4]

7 The function f is defined by

$$f(x) = x^2 - 4x + 7 \text{ for } x > 2.$$

(i) Express $f(x)$ in the form $(x - a)^2 + b$ and hence state the range of f . [3]

(ii) Obtain an expression for $f^{-1}(x)$ and state the domain of f^{-1} . [3]

The function g is defined by

$$g(x) = x - 2 \text{ for } x > 2.$$

The function h is such that $f = hg$ and the domain of h is $x > 0$.

(iii) Obtain an expression for $h(x)$. [1]

8

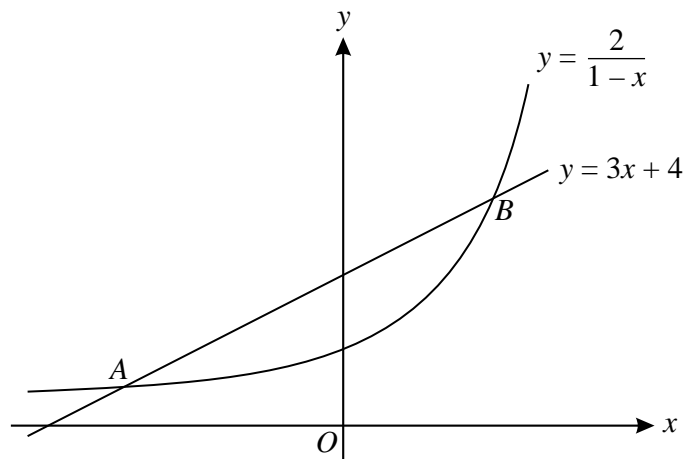

The diagram shows part of the curve $y = \frac{2}{1-x}$ and the line $y = 3x + 4$. The curve and the line meet at points A and B .

(i) Find the coordinates of A and B . [4]

(ii) Find the length of the line AB and the coordinates of the mid-point of AB . [3]

9

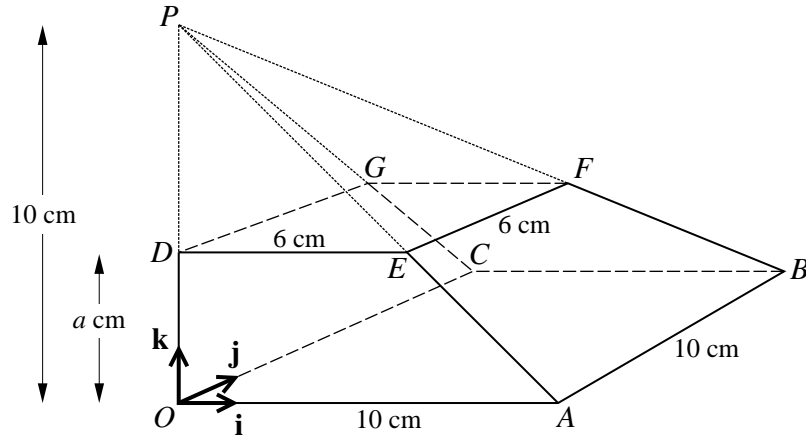

The diagram shows a pyramid $OABCP$ in which the horizontal base $OABC$ is a square of side 10 cm and the vertex P is 10 cm vertically above O . The points D, E, F, G lie on OP, AP, BP, CP respectively and $DEFG$ is a horizontal square of side 6 cm. The height of $DEFG$ above the base is a cm. Unit vectors \mathbf{i}, \mathbf{j} and \mathbf{k} are parallel to OA, OC and OD respectively.

(i) Show that $a = 4$. [2]

(ii) Express the vector \overrightarrow{BG} in terms of \mathbf{i}, \mathbf{j} and \mathbf{k} . [2]

(iii) Use a scalar product to find angle GBA . [4]

10

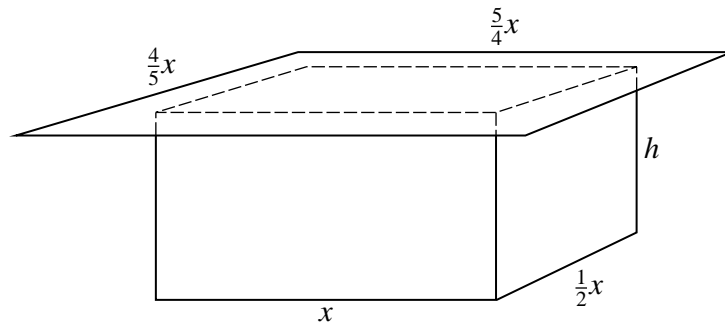

The diagram shows an open rectangular tank of height h metres covered with a lid. The base of the tank has sides of length x metres and $\frac{1}{2}x$ metres and the lid is a rectangle with sides of length $\frac{5}{4}x$ metres and $\frac{4}{5}x$ metres. When full the tank holds 4 m^3 of water. The material from which the tank is made is of negligible thickness. The external surface area of the tank together with the area of the top of the lid is $A \text{ m}^2$.

(i) Express h in terms of x and hence show that $A = \frac{3}{2}x^2 + \frac{24}{x}$. [5]

(ii) Given that x can vary, find the value of x for which A is a minimum, showing clearly that A is a minimum and not a maximum. [5]

11

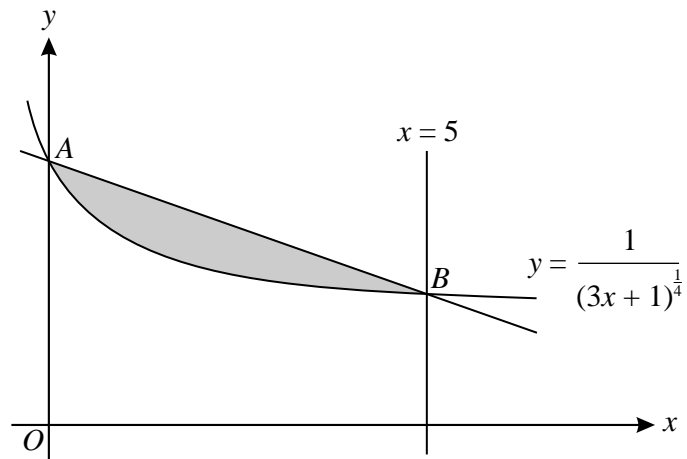

The diagram shows part of the curve $y = \frac{1}{(3x+1)^{\frac{1}{4}}}$. The curve cuts the y -axis at A and the line $x = 5$ at B .

(i) Show that the equation of the line AB is $y = -\frac{1}{10}x + 1$. [4]

(ii) Find the volume obtained when the shaded region is rotated through 360° about the x -axis. [9]

BLANK PAGE

BLANK PAGE

BLANK PAGE

Permission to reproduce items where third-party owned material protected by copyright is included has been sought and cleared where possible. Every reasonable effort has been made by the publisher (UCLES) to trace copyright holders, but if any items requiring clearance have unwittingly been included, the publisher will be pleased to make amends at the earliest possible opportunity.

University of Cambridge International Examinations is part of the Cambridge Assessment Group. Cambridge Assessment is the brand name of University of Cambridge Local Examinations Syndicate (UCLES), which is itself a department of the University of Cambridge.